

Local Safety Rodeo gets drivers winter-ready

For the last two years Manitowoc County drivers have sharpened their winter plowing skills at a local, half-day Safety Rodeo held in October. The staff test their knowledge and skills on a plowing obstacle course, a loader course, a written quiz, and a vehicle inspection test. Top scorers in each category get prizes. Everybody takes the course including regular and backup drivers and shop employees.

"At first the employees were skeptical, but now, after they went through it one year, they'd be very disappointed if we didn't do it," says County Highway Commissioner Gary Kennedy. That enthusiasm is the biggest benefit, Kennedy says, along with what they learn from taking and discussing the various tests. More importantly, the program gives employees a clear message that management cares about safety.

Program basics—obstacle course layout, written quiz, judging criteria, etc.—come from the American Public Works Association (APWA) and the WisDOT Rodeo Manual. All judges are from outside the department and include WisDOT maintenance staff, other county highway superintendents, and sheriff's staff. It takes Kennedy and his two patrol superintendents most of one day to set up the course at the County Expo grounds and prepare for the lunchtime "fry-out."

In the afternoon are sessions on equipment updates, information on the county's planned projects, and reminders about WisDOT and county winter maintenance policies. One year, for example, the automatic sanding controls supplier came and demonstrated how to operate that equipment.

"We used to have safety meetings upstairs in a big room," says Kennedy. "It was hard for the guys to sit there all day." Looking for an alternative, Kennedy and his patrol superintendents attended a 1997 Rodeo program in Marquette County. "We were really impressed with what that program accomplished."

The local newspaper prints photos of the event and the category winners. The publicity is good community relations and promotes pride among the staff.

For more information contact Highway Commissioner Gary Kennedy at 920/683-4353. For a copy of the WisDot Rodeo Manual, contact Tom Martinelli, WisDot Bureau of Highway Operations, at 608/266-3745.

Budgeting—a balancing act

by Don Walker, T.I.C. Director

The annual process of budgeting is challenging and often frustrating. With many competing needs for limited public funds, it is very difficult to prepare a balanced budget. The obvious needs overwhelm the more subtle ones when there is not enough money to go around.

It is easy to justify reconstruction for pavements that are in poor condition. These usually receive a high level of public support. On the other hand, preventive maintenance projects (crack sealing, surface treatments, etc.) are widely recognized as cost-effective, but the need isn't as apparent. It is difficult to convince some decision makers these should have priority over more obvious needs. Highway and public works managers have a responsibility to encourage balanced budgets that include cost-effective preventive maintenance projects along with reconstruction needs.

Drainage and safety projects are other opportunities to provide balance by addressing less obvious needs. When a roadway pavement needs major rehabilitation, it is important to consider drainage and safety, even though this adds cost to a project and the need for adequate drainage and safety upgrading is normally not apparent to citizen boards and the public. It is a definite challenge to include these improvements with more obvious upgrading.

The measure of truly effective managers is their ability to balance a budget between obvious needs and the not-so-obvious but essential components of public works projects. Review your 1999 budgets for appropriate safety, drainage and preventive maintenance projects.

Obstacle course layout for local Rodeo

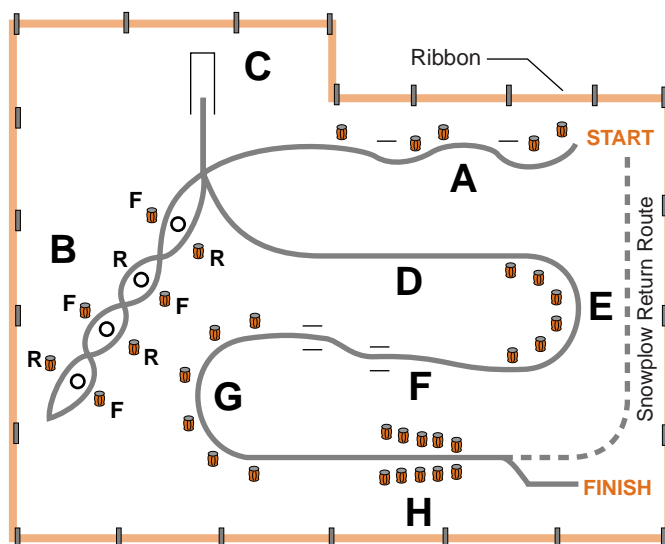

- | | |
|--|---------------------------------------|
| Event A: Parked Vehicles | Event D: Straight Line |
| Event B: Serpentine
(F – Forward)
(R – Reverse) | Event E: Outside Curve |
| Event C: Alley Dock | Event F: Offset Alley |
| | Event G: Inside Curve |
| | Event H: Diminishing Clearance |